

These documents shall not be used for any purpose or project for which it is not intended. Mead & Hunt shall be indemnified by the client and held harmless from all claims, damages, liabilities, losses, and expenses, including attorney's fees and costs, arising out of such use or reuse of the documents. In addition, unauthorized reproduction of these documents, in part or as a whole, is prohibited.

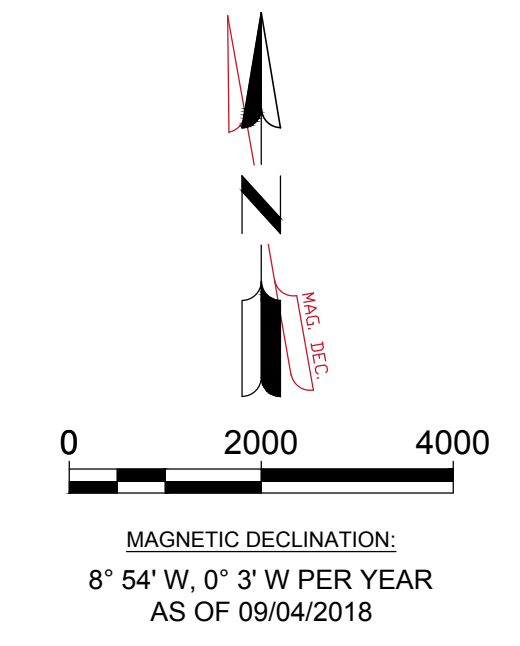
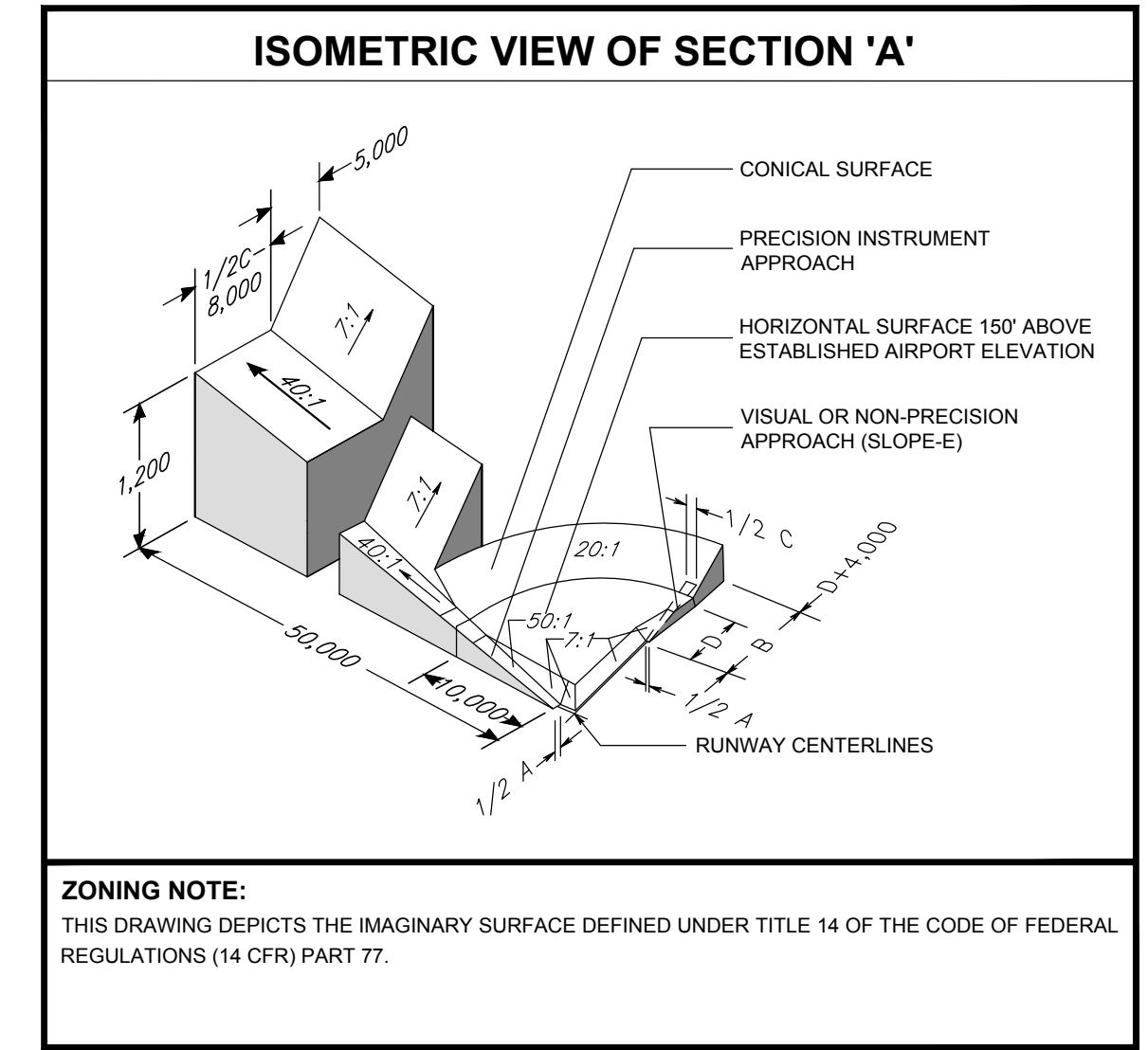
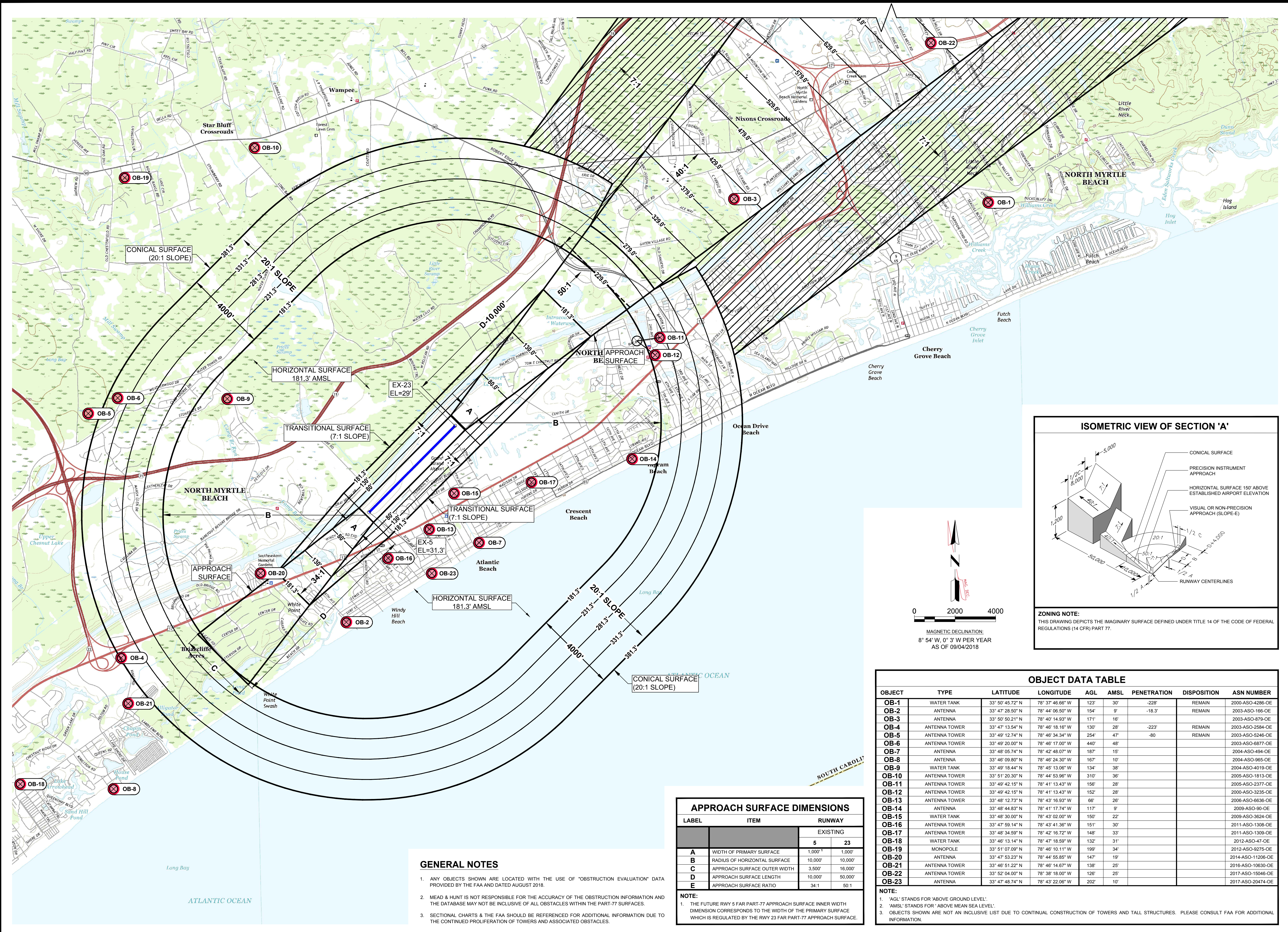

OBJECT DATA TABLE

OBJECT	TYPE	LATITUDE	LONGITUDE	AGL	AMSL	PENETRATION	DISPOSITION	ASN NUMBER
OB-1	WATER TANK	33° 50' 45.72" N	78° 37' 46.66" W	123'	30'	-228'	REMAIN	2000-ASO-4286-OE
OB-2	ANTENNA	33° 47' 28.50" N	78° 44' 06.50" W	154'	9'	-18.3'	REMAIN	2003-ASO-166-OE
OB-3	ANTENNA	33° 50' 50.21" N	78° 40' 14.93" W	171'	16'		REMAIN	2003-ASO-879-OE
OB-4	ANTENNA TOWER	33° 47' 13.54" N	78° 46' 18.16" W	130'	28'	-223'	REMAIN	2003-ASO-2584-OE
OB-5	ANTENNA TOWER	33° 49' 12.74" N	78° 46' 34.34" W	254'	47'	-80'	REMAIN	2003-ASO-5246-OE
OB-6	ANTENNA TOWER	33° 49' 20.00" N	78° 46' 17.00" W	440'	48'		REMAIN	2003-ASO-6877-OE
OB-7	ANTENNA	33° 48' 05.74" N	78° 42' 48.07" W	187'	15'		REMAIN	2004-ASO-494-OE
OB-8	ANTENNA	33° 48' 09.80" N	78° 46' 24.30" W	167'	10'		REMAIN	2004-ASO-965-OE
OB-9	WATER TANK	33° 49' 18.44" N	78° 45' 13.06" W	134'	38'		REMAIN	2004-ASO-4019-OE
OB-10	ANTENNA TOWER	33° 51' 20.30" N	78° 44' 53.96" W	310'	36'		REMAIN	2005-ASO-1813-OE
OB-11	ANTENNA TOWER	33° 49' 42.15" N	78° 41' 13.43" W	156'	28'		REMAIN	2005-ASO-3277-OE
OB-12	ANTENNA TOWER	33° 49' 42.15" N	78° 41' 13.43" W	152'	28'		REMAIN	2000-ASO-3235-OE
OB-13	ANTENNA TOWER	33° 48' 12.73" N	78° 43' 16.93" W	66'	26'		REMAIN	2006-ASO-6636-OE
OB-14	ANTENNA	33° 48' 44.83" N	78° 41' 17.74" W	117'	9'		REMAIN	2009-ASO-90-OE
OB-15	WATER TANK	33° 48' 30.00" N	78° 43' 02.00" W	150'	22'		REMAIN	2009-ASO-3624-OE
OB-16	ANTENNA TOWER	33° 47' 59.14" N	78° 43' 41.36" W	151'	30'		REMAIN	2011-ASO-1308-OE
OB-17	ANTENNA TOWER	33° 48' 34.59" N	78° 42' 16.72" W	148'	33'		REMAIN	2011-ASO-1309-OE
OB-18	WATER TANK	33° 46' 13.14" N	78° 47' 18.59" W	132'	31'		REMAIN	2012-ASO-47-OE
OB-19	MONOPOLE	33° 51' 07.99" N	78° 46' 10.11" W	199'	34'		REMAIN	2012-ASO-9275-OE
OB-20	ANTENNA	33° 47' 53.23" N	78° 44' 55.85" W	147'	19'		REMAIN	2014-ASO-11206-OE
OB-21	ANTENNA TOWER	33° 48' 51.22" N	78° 46' 14.67" W	138'	25'		REMAIN	2016-ASO-10630-OE
OB-22	ANTENNA TOWER	33° 52' 04.00" N	78° 38' 18.00" W	126'	25'		REMAIN	2017-ASO-15046-OE
OB-23	ANTENNA	33° 47' 48.74" N	78° 43' 22.06" W	202'	10'		REMAIN	2017-ASO-20474-OE

NOTE:
1. 'AGL' STANDS FOR 'ABOVE GROUND LEVEL'.
2. 'AMSL' STANDS FOR 'ABOVE MEAN SEA LEVEL'.
3. OBJECTS SHOWN ARE NOT AN INCLUSIVE LIST DUE TO CONTINUAL CONSTRUCTION OF TOWERS AND TALL STRUCTURES. PLEASE CONSULT FAA FOR ADDITIONAL INFORMATION.

APPROACH SURFACE DIMENSIONS

LABEL	ITEM	RUNWAY	
		EXISTING	
A	WIDTH OF PRIMARY SURFACE	1,000' ¹	1,000'
B	RADIUS OF HORIZONTAL SURFACE	10,000'	10,000'
C	APPROACH SURFACE OUTER WIDTH	3,500'	16,000'
D	APPROACH SURFACE LENGTH	10,000'	50,000'
E	APPROACH SURFACE RATIO	34:1	50:1

NOTE:
1. THE FUTURE RWY 5 FAR PART-77 APPROACH SURFACE INNER WIDTH DIMENSION CORRESPONDS TO THE WIDTH OF THE PRIMARY SURFACE WHICH IS REGULATED BY THE RWY 23 FAR PART-77 APPROACH SURFACE.

GENERAL NOTES

- ANY OBJECTS SHOWN ARE LOCATED WITH THE USE OF "OBSTRUCTION EVALUATION" DATA PROVIDED BY THE FAA AND DATED AUGUST 2018.
- MEAD & HUNT IS NOT RESPONSIBLE FOR THE ACCURACY OF THE OBSTRUCTION INFORMATION AND THE DATABASE MAY NOT BE INCLUSIVE OF ALL OBSTACLES WITHIN THE PART-77 SURFACES.
- SECTIONAL CHARTS & THE FAA SHOULD BE REFERENCED FOR ADDITIONAL INFORMATION DUE TO THE CONTINUED PROLIFERATION OF TOWERS AND ASSOCIATED OBSTACLES.

**GRAND STRAND AIRPORT
AIRPORT LAYOUT PLAN**
NORTH MYRTLE BEACH, SOUTH CAROLINA

REVISIONS

MAH PROJ. NO: 4055600-160019.01
FEDERAL NO: Value
LOG ID: CRE
DATE: 9/18
DESIGNED BY: AEF
DRAWN BY: GAM
CHECKED BY: SADW
DO NOT SCALE DRAWINGS
SHEET CONTENTS
**AIRPORT AIRSPACE
DRAWING**
SHEET NO.

These documents shall not be used for any purpose or project for which it is not intended. Mead & Hunt shall be indemnified by the client and held harmless from all claims, damages, liabilities, losses, and expenses, including attorney's fees and costs, arising out of such reuse or use of the documents. In addition, unauthorized reproduction of these documents, in part or as a whole, is prohibited.

**GRAND STRAND AIRPORT
AIRPORT LAYOUT PLAN**
NORTH MYRTLE BEACH, SOUTH CAROLINA

REVISIONS

M&H PROJ. NO: 4055600-160019.01
FEDERAL NO: Value
LOC ID: CRE
DATE: 9/18
DESIGNED BY: AEF
DRAWN BY: GAM
CHECKED BY: SADW
DO NOT SCALE DRAWINGS

SHEET CONTENTS
AIRPORT AIRSPACE
DRAWING CONT

SHEET NO.

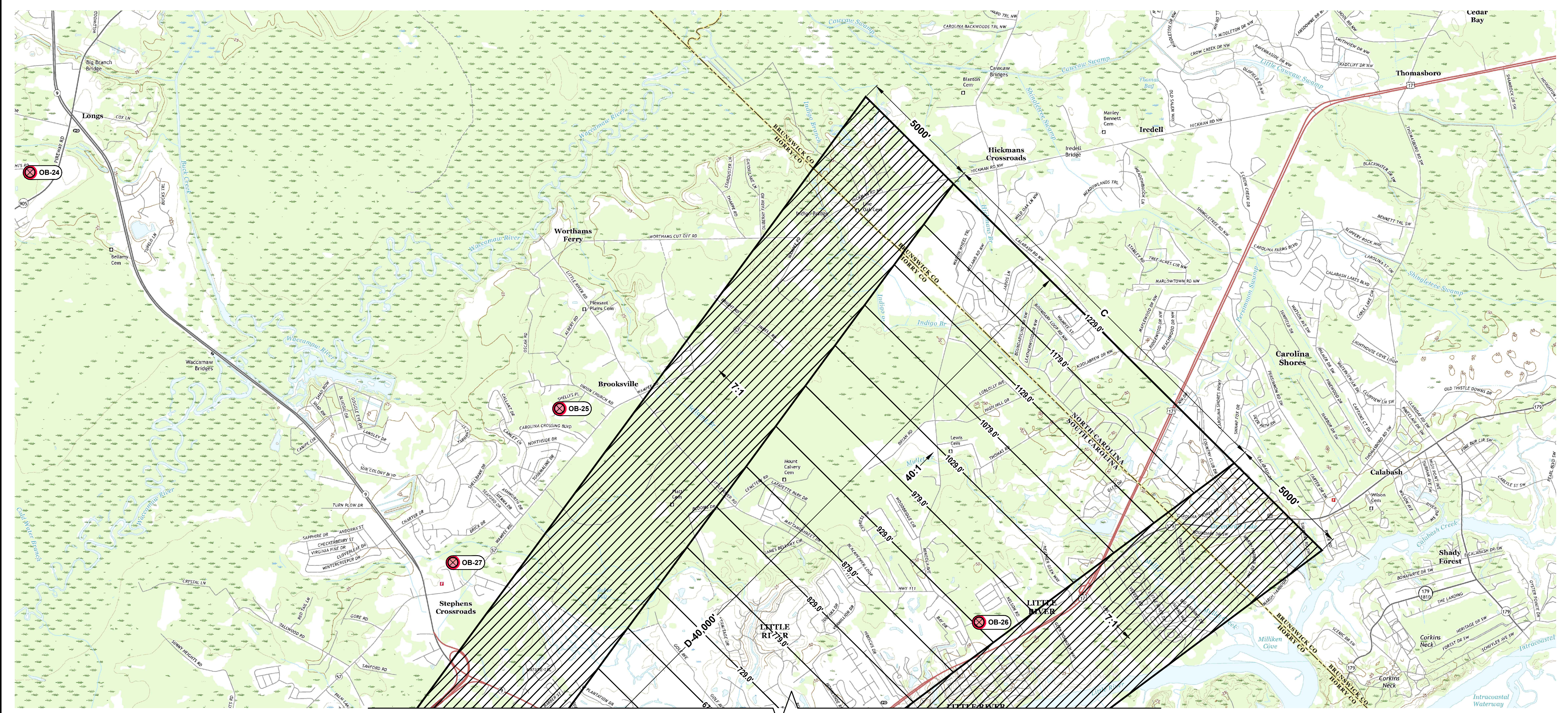

OBJECT DATA TABLE								
OBJECT	TYPE	LATITUDE	LONGITUDE	AGL	AMSL	PENETRATION	DISPOSITION	ASN NUMBER
OB-24	ANTENNA	33° 55' 57.20" N	78° 44' 20.10" W	270'	38'	-75	REMAIN	2003-ASO-363-OE
OB-25	ANTENNA TOWER	33° 54' 18.14" N	78° 40' 08.68" W	285'	41'	-55	REMAIN	2003-ASO-5249-OE
OB-26	WATER TANK	33° 52' 48.93" N	78° 36' 49.85" W	139'	51'	-743	REMAIN	2010-ASO-4562-OE
OB-27	ANTENNA TOWER	33° 53' 17.59" N	78° 41' 01.45" W	255'	38'	-88	REMAIN	2013-ASO-9040-OE

NOTE:
1. 'AGL' STANDS FOR 'ABOVE GROUND LEVEL'.
2. 'AMSL' STANDS FOR 'ABOVE MEAN SEA LEVEL'.
3. OBJECTS SHOWN ARE NOT AN INCLUSIVE LIST DUE TO CONTINUAL CONSTRUCTION OF TOWERS AND TALL STRUCTURES. PLEASE CONSULT FAA FOR ADDITIONAL INFORMATION.

GENERAL NOTES:

- ANY OBJECTS SHOWN ARE LOCATED WITH THE USE OF "OBSTRUCTION EVALUATION" DATA PROVIDED BY THE FAA AND DATED AUGUST 2018.
- MEAD & HUNT IS NOT RESPONSIBLE FOR THE ACCURACY OF THE OBSTRUCTION INFORMATION AND THE DATABASE MAY NOT BE INCLUSIVE OF ALL OBSTACLES WITHIN THE PART-77 SURFACES.
- SECTIONAL CHARTS & THE FAA SHOULD BE REFERENCED FOR ADDITIONAL INFORMATION DUE TO THE CONTINUED PROLIFERATION OF TOWERS AND ASSOCIATED OBSTACLES.

APPROACH SURFACE DIMENSIONS		
LABEL	ITEM	RUNWAY
		EXISTING
		5
		23
A	WIDTH OF PRIMARY SURFACE	1,000' ¹ 1,000'
B	RADIUS OF HORIZONTAL SURFACE	10,000' 10,000'
C	APPROACH SURFACE OUTER WIDTH	3,500' 16,000'
D	APPROACH SURFACE LENGTH	10,000' 50,000'
E	APPROACH SURFACE RATIO	34:1 50:1

NOTE:
1. THE FUTURE RWY 5 FAR PART-77 APPROACH SURFACE INNER WIDTH DIMENSION CORRESPONDS TO THE WIDTH OF THE PRIMARY SURFACE WHICH IS REGULATED BY THE RWY 23 FAR PART-77 APPROACH SURFACE.

